

FOR CUSTOMER USE

NOM	PIPE SIZE		NECK OD	WIDTH	SPRING WASHER QTY/BOLT
	DI	IPS			
	A	A	C	D	H
6"	6.90	6.63	4.50	10.00	4
8"	9.05	8.63	4.50	10.00	5
8"	9.05	8.63	6.63	12.00	5
10"	11.10	10.75	4.50	10.00	6
10"	11.10	10.75	6.63	12.00	6
12"	13.20	12.75	4.50	10.00	6
12"	13.20	12.75	6.63	12.00	6

REVISIONS			
REV.	DESCRIPTION	DATE	APPROVED
0	INITIAL RELEASE	05/04/18	MLC
1	UPDATED SHEET FORMAT	5/7/2018	MLC

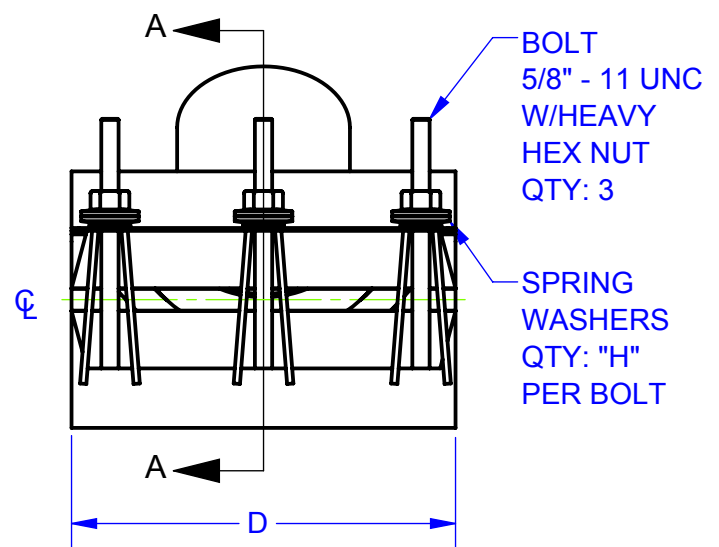
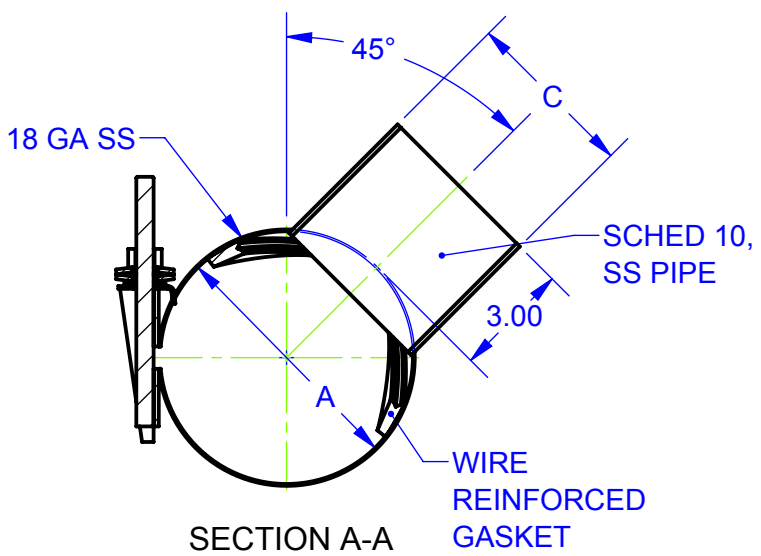
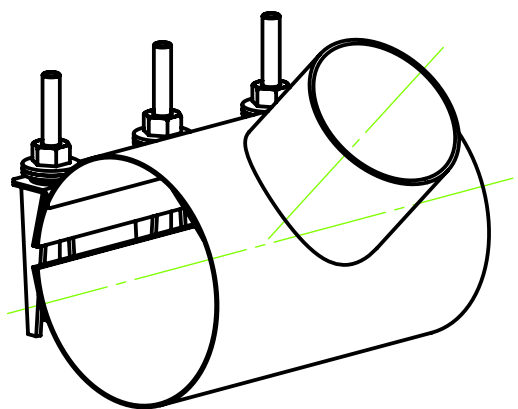

NOTE:
 1. ALL MATERIAL TYPE 304 STAINLESS STEEL UNLESS NOTED.
 2. ALL WELDS PASSIVATED FOR MAXIMUM CORROSION RESISTANCE.

PROPRIETARY NOTICE THIS DRAWING CONTAINS CONFIDENTIAL PROPRIETARY INFORMATION AND IS THE PROPERTY OF ROMAC IND., INC. IT IS TO BE USED ONLY FOR THE PURPOSE FOR WHICH IT WAS SUBMITTED AND SHALL NOT HAVE ITS INFORMATION DISCLOSED OR REPRODUCED IN WHOLE OR IN PART FOR ANY PURPOSE WITHOUT PRIOR WRITTEN PERMISSION OF ROMAC IND., INC.		UNLESS OTHERWISE SPECIFIED • DIMENSIONS ARE IN INCHES • TOLERANCES ARE ON: 1 PL DECIMALS ± 0.060 2 PL DECIMALS ± 0.030 3 PL DECIMALS ± 0.010 ANGLES ± 1° FRACTIONS ± 1/64 • DIMENSIONS IN () ARE FOR REFERENCE ONLY		SIGNATURES DRAWN Matt Clegg APPROVED Sam Hill		DATE 05/07/2018 5/7/2018		ROMAC INDUSTRIES INC. TITLE BP SEWER SADDLE IPS AND DI SIZE						
MODEL NAME: BP SEWER SADDLE MODEL CAD #: CAD-041045 VERSION:		CONFIGURATION NAME: 4.80 X .75		THIRD ANGLE PROJECTION		LEGACY DRAWING #: DRAWING FILE NAME: BP SEWER SADDLE IPS AND DI - CUST DWG		DWG. NO. CAD-041044		SIZE A	REV. NO. R1	SCALE 1:5	SHEET 1 OF 1	AUTHOR: Niels Thogersen

RELEASED