

NOMINAL SIZE (IN)	PIPE OD (IN)	RADIUS (IN)	LENGTH (IN)	"N" # OF WASHERS
4	4.50	2.25	6.92	2
	4.80	2.40	7.17	2
6	6.63	3.32	8.90	2
	6.90	3.45	8.93	2
8	8.63	4.32	11.04	3
	9.05	4.53	11.13	3

REVISIONS			
REV.	DESCRIPTION	DATE	EDITOR
R2	A	4/12/22	RBA

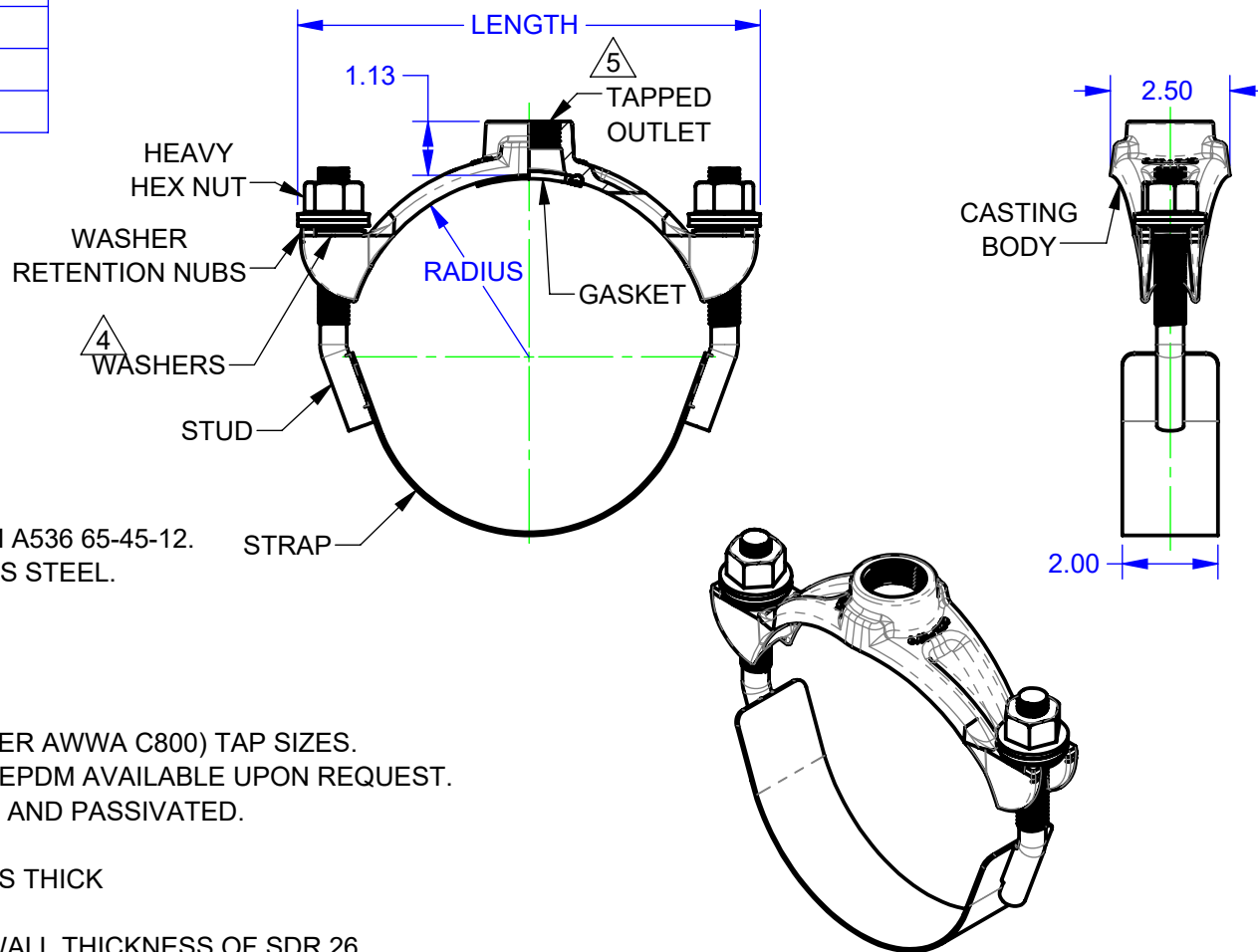

NOTES:

- CASTING BODY: DUCTILE IRON PER ASTM A536 65-45-12.
- STRAP, STUD, & NUT: TYPE 304 STAINLESS STEEL.
- STUD & NUT: 5/8-11 UNC.
- WASHERS:
 - 1 EACH OF: 304SS & ACETAL PLASTIC.
 - "N" AMOUNT OF SPRING WASHERS.
- OUTLET: UP TO 1" "IP" (NPT) OR 1" "CC" (PER AWWA C800) TAP SIZES.
- GASKET: NBR PER ASTM D2000 MBC 610. EPDM AVAILABLE UPON REQUEST.
- WELDING: GMAW. CHEMICALLY CLEANED AND PASSIVATED.
- COATING:
 - A** • CASTING: NYLON COATING 10-14 MILS THICK
 - NUTS: BLACK EPOXY E-COAT
- FOR USE ON HDPE PIPE WITH MINIMUM WALL THICKNESS OF SDR 26.

FOR CUSTOMER USE

RELEASED

<p>PROPRIETARY NOTICE</p> <p>THIS DRAWING CONTAINS CONFIDENTIAL PROPRIETARY INFORMATION AND IS THE PROPERTY OF ROMAC IND., INC. IT IS TO BE USED ONLY FOR THE PURPOSE FOR WHICH IT WAS SUBMITTED AND SHALL NOT HAVE ITS INFORMATION DISCLOSED OR REPRODUCED IN WHOLE OR IN PART FOR ANY PURPOSE WITHOUT PRIOR WRITTEN PERMISSION OF ROMAC IND., INC.</p>		<p>UNLESS OTHERWISE SPECIFIED</p> <ul style="list-style-type: none"> DIMENSIONS ARE IN INCHES DRAWING NOT TO SCALE. 		<p>SIGNATURES</p> <p>DRAWN Rosa Bartsch</p> <p>APPROVED Caitlin Boone</p>		<p>DATE</p> <p>4/12/2022</p> <p>4/12/2022</p>		<p>ROMAC INDUSTRIES INC.</p> <p>TITLE DI SADDLES 101NH, SMALL TAP, 4" - 8"</p>	
<p>MODEL NAME: SERVICE SADDLE, ASSEM, DI, 101, S-BOSS, 07.60 IN MODEL CAD #: CAD-050640</p>		<p>CONFIGURATION NAME: HDPE</p>		<p>THIRD ANGLE PROJECTION</p>		<p>LEGACY DRAWING #: N/A DRAWING FILE NAME: SERVICE SADDLE, ASSEM, DI, 101, S-BOSS, HDPE, 4 - 8 IN</p>		<p>AUTHOR: Kevin Tam</p>	
<p>DWG. NO. CAD-023168</p>		<p>SIZE A</p>		<p>REV. NO. R2</p>		<p>SCALE NTS</p>		<p>SHEET 1 OF 1</p>	