

FOR CUSTOMER USE

SIZE (INCH)	TOTAL GASKET RANGE	INNER GASKET OD RANGE	OUTER GASKET OD RANGE	BODY OD		HEIGHT		LENGTH		BODY LENGTH	BOLT DIA.	MAX DEFLECTION PER SIDE (DEGREES)	WORKING PRESSURE (PSI)	WEIGHT (LBS)
				ØA	B	C	D	E						
2"	2.12-2.90	2.12-2.55	2.50-2.90	5.8	6.8	6.4	4.0	1/2-13	5	305	9			
3"	3.13-4.13	3.13-3.63	3.63-4.13	7.2	8.4	8.4	6.0	1/2-13	5	305	12			
4"	4.40-5.60	4.40-5.05	4.95-5.60	9.0	10.2	11.2	8.0	5/8-11	5	305	28			
6"	6.60-7.60	6.60-7.15	7.10-7.60	11.0	12.2	11.2	8.0	5/8-11	5	305	34			
8"	8.60-9.75	8.60-9.20	9.10-9.75	13.1	14.3	11.2	8.0	5/8-11	5	305	36			
10"	10.70-11.90	10.70-11.30	11.25-11.90	15.3	16.5	11.2	8.0	5/8-11	5	260	57			
10"XL	11.00-12.20	11.00-11.65	11.55-12.20	15.6	16.8	11.2	8.0	5/8-11	5	260	59			
12"	12.70-13.80	12.70-13.30	13.15-13.80	17.2	18.4	11.2	8.0	5/8-11	5	260	62			
12"XL	13.50-14.40	13.15-13.80	13.75-14.40	17.8	19.0	11.2	8.0	5/8-11	5	260	64			
16"	17.10-19.20	17.10-18.19	18.11-19.20	25.3	24.8	15.6	12.0	5/8-11	4	** 260	135			

REVISIONS			
REV.	DESCRIPTION	DATE	EDITOR
1	UPDATED FOR MACRO HP	6/17/2014	B. CUMIC
2	UPDATED: FORMAT, DIMENSIONS FOR 2" AND 3", WEIGHTS, AND MIN INSERTION. ADDED GASKET RANGES, DEFLECTION, MATERIAL NOTES, AND PRESSURE.	10/10/2024	MLW
3	ADDED 16". ALL GASKETS NOW NESTED STYLE.	2/14/2025	MSL

- NOTES:
- ALL MATERIAL DUCTILE IRON PER ASTM A536, GRADE 65-45-12, OR 60-40-18, UNLESS OTHERWISE SPECIFIED.
 - COATING:
 - BODY: NSF61 CERTIFIED FUSION BONDED EPOXY LINED AND COATED.
 - BOLT GUIDE AND END RING: E-COAT EPOXY
 - FASTENER MATERIAL: TYPE 304 STAINLESS STEEL IS STANDARD. TYPE 316 STAINLESS STEEL AVAILABLE ON REQUEST.
 - GASKETS: NSF61 CERTIFIED EPDM GASKETS ARE STANDARD, NSF61 CERTIFIED NBR GASKETS AVAILABLE ON REQUEST.
 - TEST PRESSURE IS 1.5X WORKING PRESSURE MAX.
 - PIPE INSERTION EACH SIDE:
 - 2"-3": 2.0 INCHES MIN.
 - 4"-12": 2.5 INCHES MIN.
 - 16": 4.0 INCHES MIN.
 - 4"-12" LOW RANGE GASKETS ARE AVAILABLE FOR SMALLER PIPE DIAMETERS. MAXIMUM WORKING PRESSURE WITH LR GASKETS IS 200 PSI. SEE CATALOG FOR DETAILS.
 - * 16" MACRO HP HAS DOUBLE THE QUANTITY OF END RING BOLTS AND ARMORS AS THE 12" AND SMALLER SIZES.
 - ** 16" MACRO HP WORKING PRESSURE RATINGS: OUTER GASKET - 260 PSI, INNER GASKET - 200 PSI.
 - ALL SIZES ARE NSF61 CERTIFIED AS STANDARD.

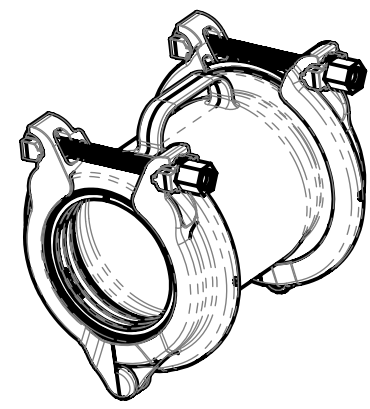
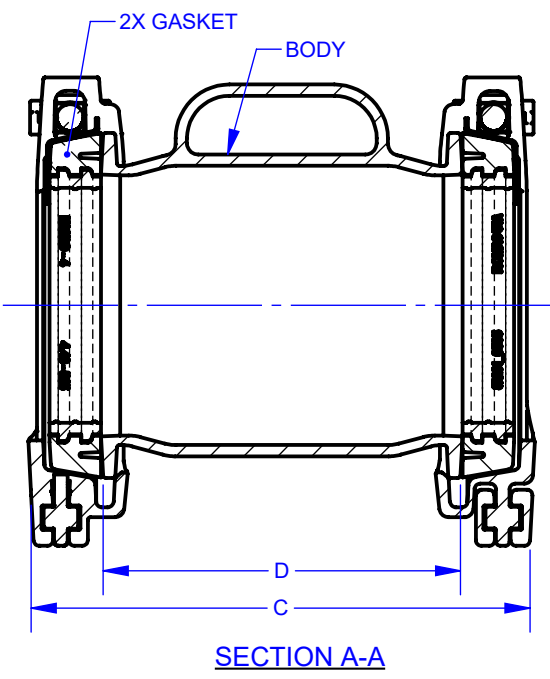
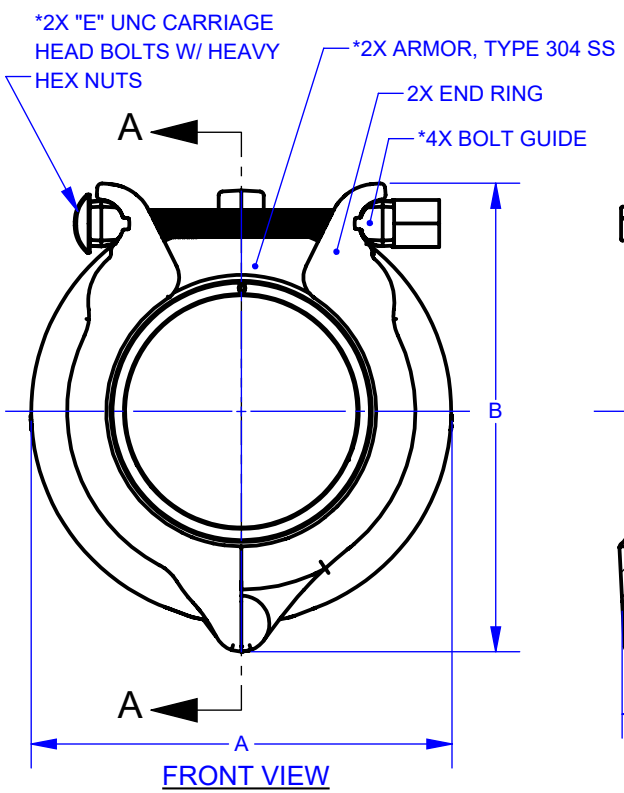

PROPRIETARY NOTICE THIS DRAWING CONTAINS CONFIDENTIAL PROPRIETARY INFORMATION AND IS THE PROPERTY OF ROMAC IND., INC. IT IS TO BE USED ONLY FOR THE PURPOSE FOR WHICH IT WAS SUBMITTED AND SHALL NOT HAVE ITS INFORMATION DISCLOSED OR REPRODUCED IN WHOLE OR IN PART FOR ANY PURPOSE WITHOUT PRIOR WRITTEN PERMISSION OF ROMAC IND., INC.		UNLESS OTHERWISE SPECIFIED • DIMENSIONS ARE IN INCHES • DRAWING NOT TO SCALE		SIGNATURES DRAWN Branko Cumic APPROVED Logan Bronemann		DATE 01/26/2009 2/18/2025		ROMAC INDUSTRIES INC. TITLE MACRO HP, WIDE RANGE COUPLING, 2-16 INCH			
CONFIGURATION NAME: Default				THIRD ANGLE PROJECTION		DWG. NO. B3154-A		SIZE A	REV. NO. R1	SCALE NTS	SHEET 1 OF 1
CAD #: CAD-071691						AUTHOR: Branko Cumic					

RELEASED