

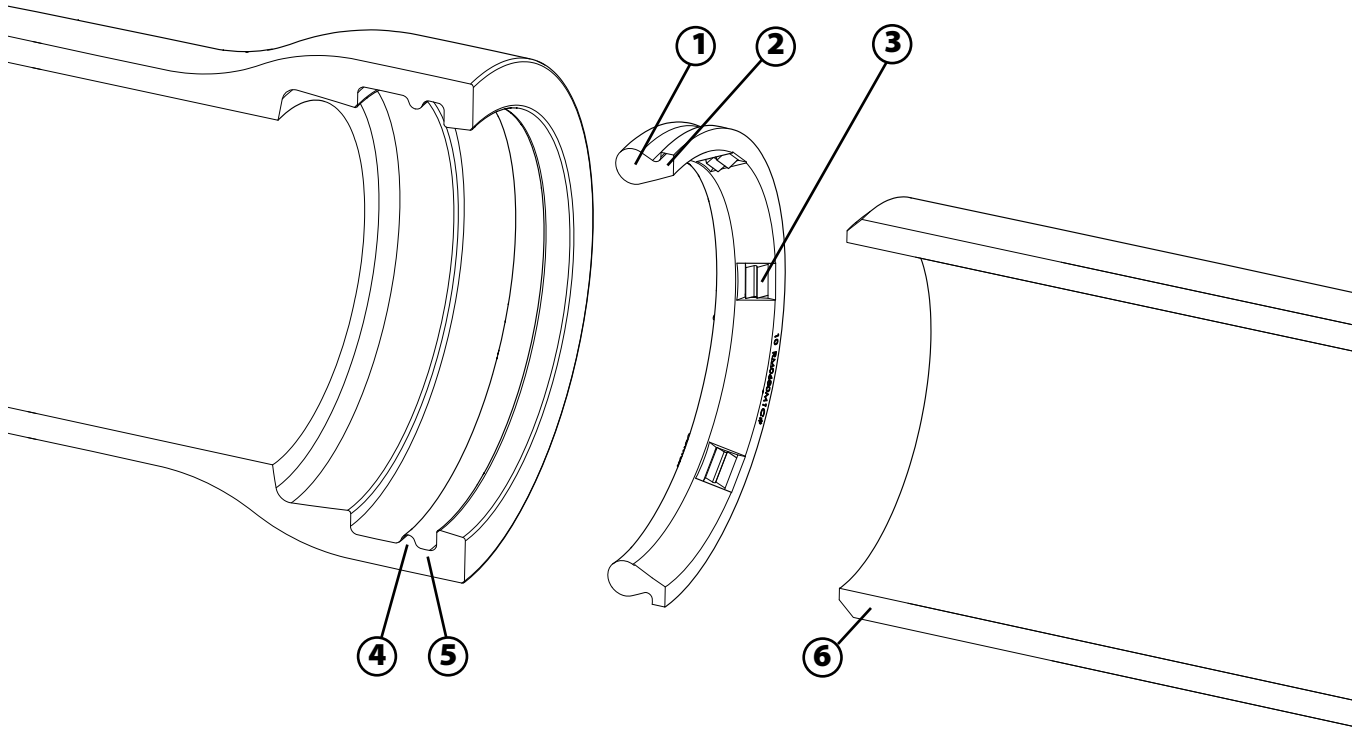

Piranha™ Restraint Gasket

Joint Restraint for Tyton® Ductile Iron Bell and Spigot Push-On Joints.

Read installation instructions first before installing. Check parts to ensure that no damage has occurred during transit and that no teeth are missing. Also check the diameter of the pipe and the size marked on the Piranha to ensure you have the proper size.



COMMON TERMS

1. **Sealing Bulb:** Portion of the gasket that creates and maintains a seal in the joint.
2. **Gasket Heel:** Portion of the gasket that helps prevent the gasket from being dislodged during installation.
3. **Stainless Steel Teeth:** The portion of the gasket that provides restraint in the joint.
4. **Bell Ridge:** Feature in the bell that allows the teeth to transfer the restraint load.
5. **Gasket Race:** Feature in the bell that retains the gasket during installation.

TYTON® and TYTON®/NITC are registered trademarks of Tyton Industries, LLC. All other trademarks are the property of their respective owners. ROMAC is an affiliate of Tyton Industries, LLC. ROMAC is not affiliated with Romac the Piranha Gasket.

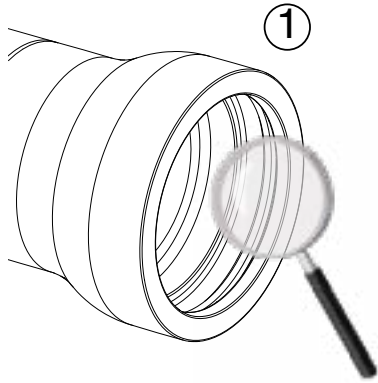

Step 1 • Confirm that the joint is a *Tyton® Joint.

Inspect the pipe and gasket ensuring that it is in good order, free from debris, and clean in all areas. Check all surfaces inside and out. Remove any edges that could damage the gasket, and remove foreign matter such as tar, paint, rust and dirt in the gasket groove.

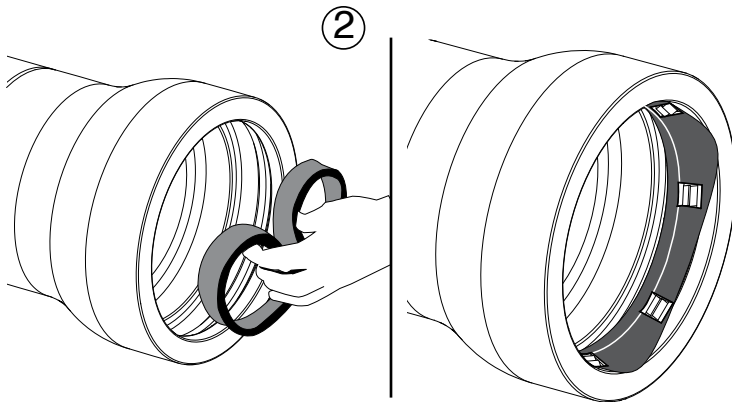

Step 2 • Loop the gasket and insert into the socket with rounded bulb-end first. Press the gasket until it is fully seated inside the gasket race. Large gaskets may require multiple loops evenly spaced around the gasket.

NOTES ON FIELD CUT PIPE

When field cuts are anticipated, Romac recommends using factory gauged pipe.

If a field cut is necessary, measure the pipe OD at the cut to ensure that it falls within the range shown below.

SUITABLE PIPE OD FOR FIELD CUTS

NOMINAL PIPE SIZE (inches)	PIPE DIAMETER (inches)		PIPE CIRCUMFERENCE (inches)	
	MIN	MAX	MIN	MAX
4	4.74	4.86	14.88	15.28
6	6.84	6.96	21.47	21.88
8	8.99	9.11	28.25	28.63
10	11.04	11.16	34.69	35.06
12	13.14	13.26	41.28	41.66
14	15.22	15.35	47.81	48.22
16	17.32	17.45	54.41	54.81
18	19.42	19.55	61.00	61.41
20	21.52	21.65	67.59	68.03
24	25.72	25.85	80.78	81.22

*TYTON® and TYTON JOINT® are registered trademarks of the United States Pipe and Foundry, LLC which has no affiliation with Romac Industries, Inc. United States Pipe and Foundry Company, LLC does not manufacture, or endorse the Piranha Gasket.

NOTES ON FIELD CUT PIPE (cont.)

Bevel the edge of the field cut pipe .25" at a 30 degree angle. Round the edge and remove sharp edges which could damage the gasket. See drawing below. **NOTE:** Break the edges of the bevel.

SPIGOT END

RECOMMENDED BEVEL

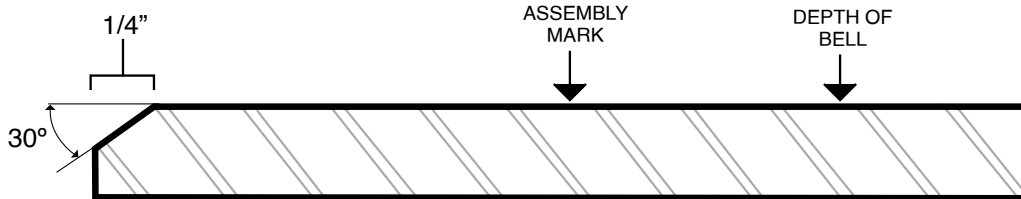

Measuring from the cut end of the pipe, make an assembly mark according to the table below.

ASSEMBLY MARK & ALLOWABLE DEFLECTION

NOMINAL PIPE SIZE (inches)	LOCATION OF ASSEMBLY MARK (inches)	MAX JOINT DEFLECTION (degrees)	DEFLECTION OF 18 FOOT LENGTH (inches)	APPROX. RADIUS OF CURVE PRODUCED BY SUCCESSION OF JOINTS - 18 FOOT LENGTHS (feet)
4	2.75	5	19	205
6	2.94			
8	3.25			
10	3.31			
12	3.31			
14	4.56	4	15	
16	4.56			
18	4.56			
20	5.06	2.5	9.5	412
24	5.50			

When no deflection is necessary, measure the depth of the bell and make a mark on the spigot at this depth. This will indicate when the pipe is fully homed. When deflection is necessary use the table to mark the insertion depth and deflect after insertion.

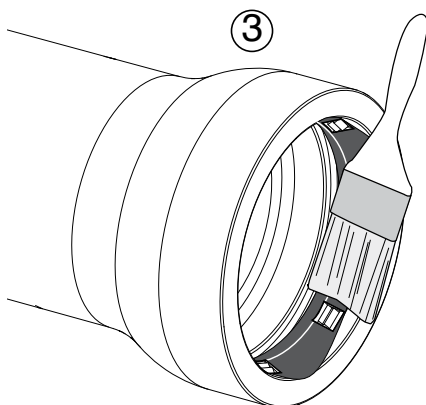

Step 3 • Check to see that the plain end of the pipe is properly beveled and free of any square or sharp edges which may interfere with, or damage the gasket. Lubricate the ID (exposed face) of the gasket and approximately six inches of the Spigot OD with an approved lubricant per ANSI/AWWA C111/A21.11. Use of soapy water as a lubricant is not recommended.

NOTE: Do **not** lubricate the bell socket or the surface of the gasket that contacts the bell socket.

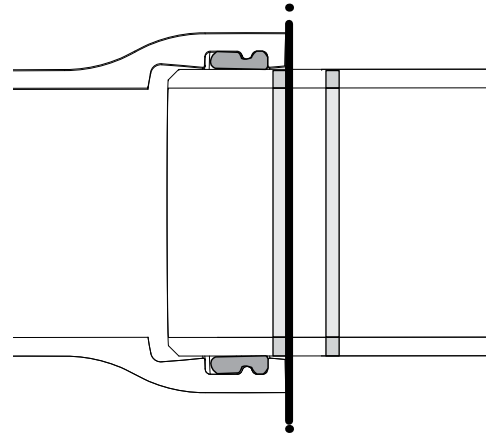
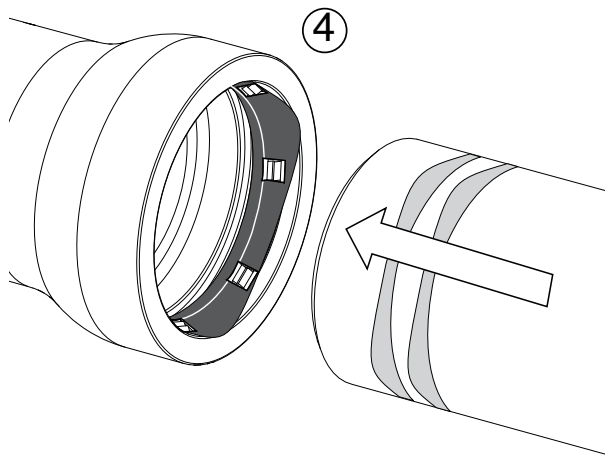

**INSERT TO FIRST
ASSEMBLY STRIPE**

Step 4 • Insert the spigot end into the bell and keep both sections of pipe aligned without deflection. Insert pipe until the entire first assembly stripe has passed the outer face of the bell. The second installation mark indicates when the pipe is fully homed.

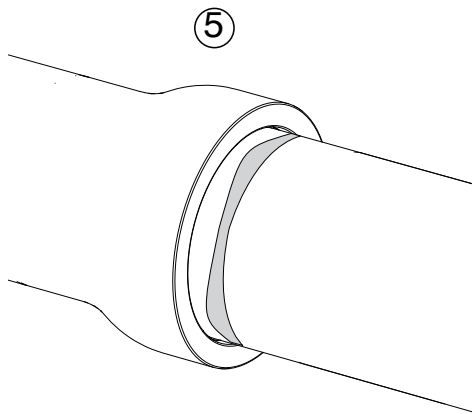

Step 5 • After insertion to the first assembly stripe, the pipe can be deflected. See table on previous page for maximum allowable deflection.

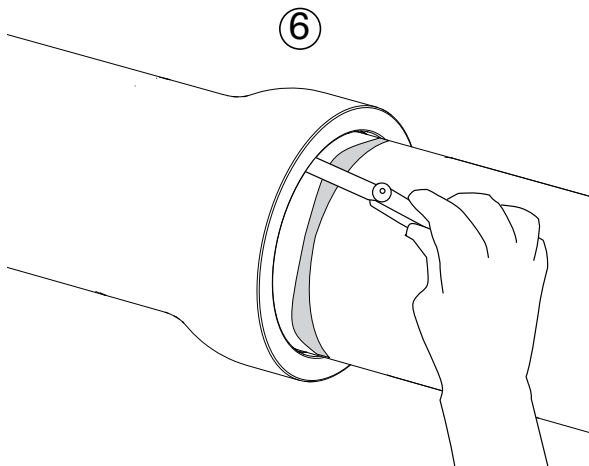

Step 6 • Use a feeler gauge to ensure that the gasket has not been dislodged from the gasket cavity during installation.

ROMAC Piranha™ Installation Instructions

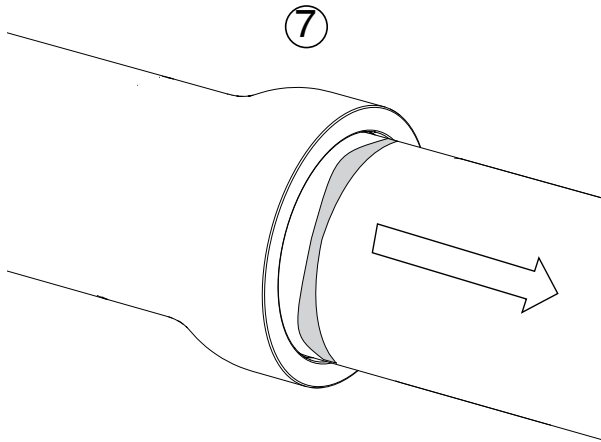

Step 7 • Apply a setting force in the opposite direction of assembly to engage teeth. Up to 0.25" of extension can be expected to set teeth.

NOTE: The Piranha gasket is not to be reused.

ROMAC Piranha™ Disassembly Instructions

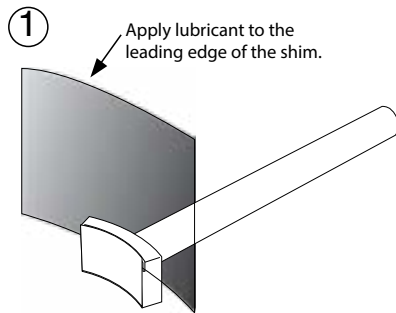

NOTE: It will make installation of shims easier if pipe can be pushed together a little to disengage the teeth of gasket from spigot end.

Step 1 • While wearing gloves to protect hands, insert an extractor shim into the slot of the tool. Apply lubricant over the leading edge of the shim. Being sure to wear safety glasses, commence at the bottom of the joint.

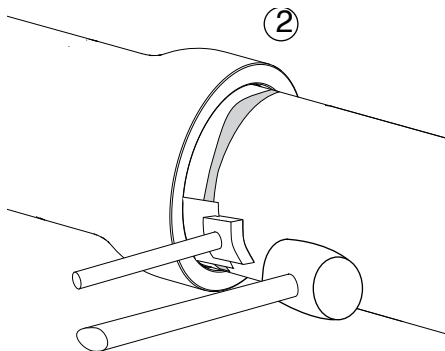

Step 2 • Drive shim under the gasket by striking the tool with a heavy hammer. Continue driving shims under the gasket around the entire circumference of the joint. Keep the gap between the shims to a minimum.

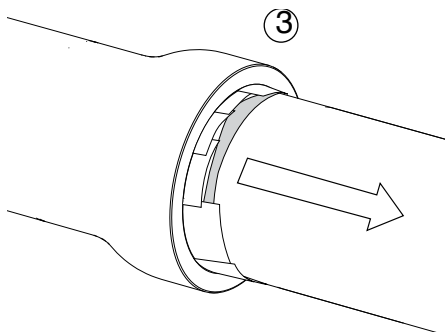

Step 3 • Insert the last shim so that it is overlapped by the shims on either side. After all shims have been properly installed, the joint can be separated by pulling, using a cable and a backhoe or other equipment to force joint separation.

Do not reuse the Piranha™ Gasket.

PRECAUTIONS

1. The pressure rating of the Piranha Restraint Gasket does not exceed the pressure rating of the pipe in which it is installed.
2. The Piranha Restraint Gasket is not designed to be reused.
3. The Piranha is not designed for above ground installations.
4. To achieve maximum joint deflection. Maintain a straight alignment in the joint during assembly. Do not fully “home” the joint if deflection is required. Set the allowable deflection after assembling the joint to the first assembly mark.
5. For field cut pipe, condition the pipe as explained in the “Notes on Field Cut Pipe” section of the installation instructions.
6. Failure to properly lubricate will increase installation forces drastically and increases the risk of tearing or dislodging the gasket during installation.
7. Failure to properly bevel plain end, or spigot end may result in the gasket becoming dislodged during assembly.
8. For installation in cold weather, keep the temperature of the Piranha gasket above 40°F.
9. Approximately twice as much assembly force may be required to assemble a Piranha Gasket joint as is required for a conventional push-on joint.
10. Although disassembly of the joint can be achieved, Romac does not recommend use of the Piranha if joint disassembly is anticipated.
11. Piranha is not for use when the plain end pipe has a thick exterior coating such as epoxy, concrete or tape wrap. If an epoxy coating thickness of 6mils or concrete thickness of 2mils exists, the coating or tape wrap should be removed prior to installation. OD of pipe should be checked to ensure it is within the specifications shown in “Suitable Pipe OD for Field Cuts” table.
12. Do not use with corroded pipe.
13. Do not use Piranha Restraint Gaskets to provide electrical joint conductivity for thawing. Such use may damage the gasket.
14. ROMAC has not tested Piranha gaskets with gray iron or plastic piping products and, therefore, cannot recommend or warrant the use of Piranha gaskets with gray iron (pipe, fittings or valves) or plastic (pipe or fittings).
15. Use in casings: Piranha Gaskets may be used in systems with straight casings by pulling (not pushing) the pipe through the casing. Pushing the pipe may result in the pipe becoming too far engaged into the bell, restricting deflection.
16. For vertical installations, the joint must be kept extended so as to not allow the teeth to become disengaged from the pipe. Failure to keep vertical joints extended can result in joint separation.
17. Concrete Thrust blocks and other restraint methods are not required to be used with Piranha Gaskets when Piranha Gaskets are used in a designed thrust restraint system. Romac recommends using “The Thrust Restraint Design for Ductile-Iron Pipe published

COMMON INSTALLATION ERRORS

1. Failure to properly bevel pipe will result in gasket becoming dislodged.
2. Failure to properly lubricate will increase installation forces drastically and could cause the gasket to tear or become dislodged.
3. Deflection during insertion may cause the gasket to tear or become dislodged